



EDISON OPTO CORPORATION

Edixeon Star

1W High Power LED

Date : 2005/04/30

Version : 2.1

Device No. : 3-RD-01-E0007



EDISON OPTO CORPORATION

*Office: 4F, No. 800, Chung-Cheng Rd,
Chung-Ho, Taipei 235, Taiwan, R.O.C.*

Tel: 886-2-8227-6996

Fax: 886-2-8227-6997

<http://www.edison-opto.com.tw>

Features

- Long operating life (up to 100,000 hours)
- More Energy Efficient than incandescent and most halogen lamps
- Low forward voltage operated
- Instant light (Less than 100 ns)
- No UV
- High ESD protection.(More than 8kV).

Typical Applications

- Reading lights
- Portable flashlight
- Uplighters and Downlighters
- Bollards / Security / Garden lighting
- Indoor and Outdoor Commercial lighting
- LCD Backlights / Light guides
- General lighting

Edixeon Emitter group

White Housing	<i>Emitter</i>	White	Warm White	Red	Green
	Lambertian	EDSW-1LA1	EDSX-1LA1	EDSR-1LA3	EDST-1LA2
	Batwing	EDSW-1BA1	EDSX-1BA1	EDSR-1BA3	EDST-1BA2
	Side Emitting	EDSW-1SA1	EDSX-1SA1	EDSR-1SA3	EDST-1SA2
	Focusing	EDSB-1FA1	EDSX-1FA1	EDSR-1FA1	EDST-1FA1
	<i>Emitter</i>	Blue	Red Orange	Amber	
	Lambertian	EDSB-1LA1	EDSO-1LA3	EDSA-1LA3	
	Batwing	EDSB-1BA1	EDSO-1BA3	EDSA-1BA3	
	Side Emitting	EDSB-1SA1	EDSO-1SA3	EDSA-1SA3	
	Focusing	EDSB-1FA1	EDSO-1FA1	EDSA-1FA1	

Lambertian Star Package Outlines

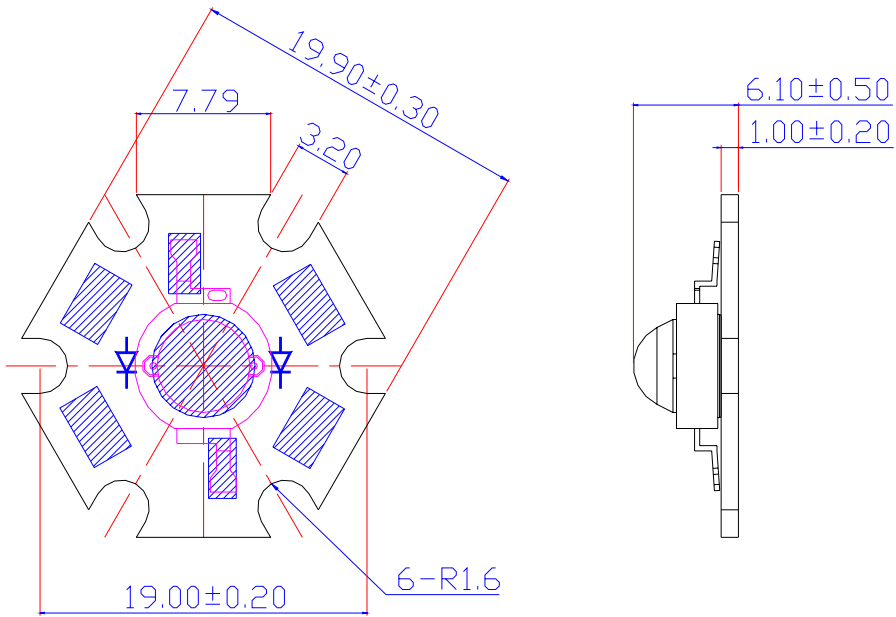

Side Emitting Star Package Outlines

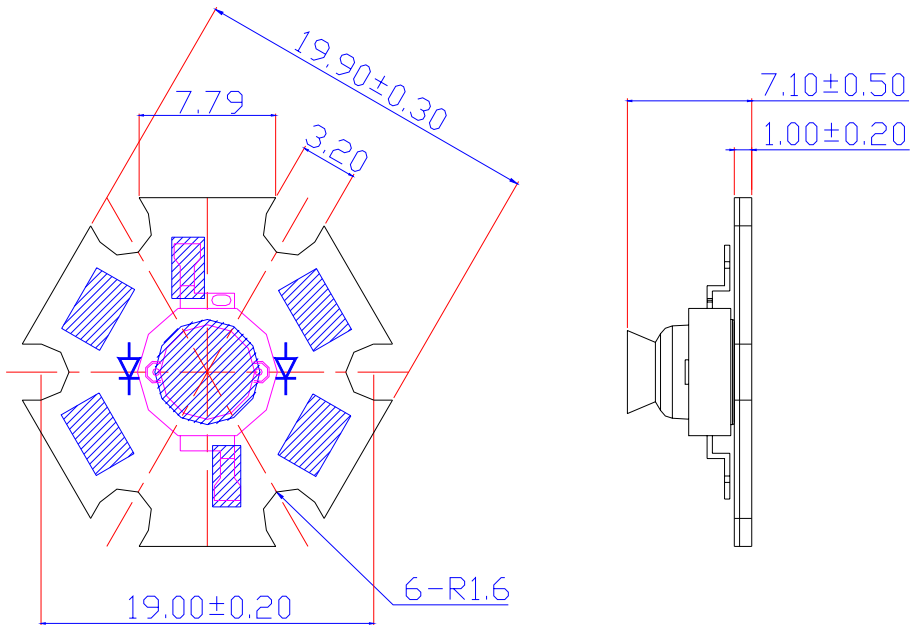

Unit:mm

Batwing Star Package Outlines

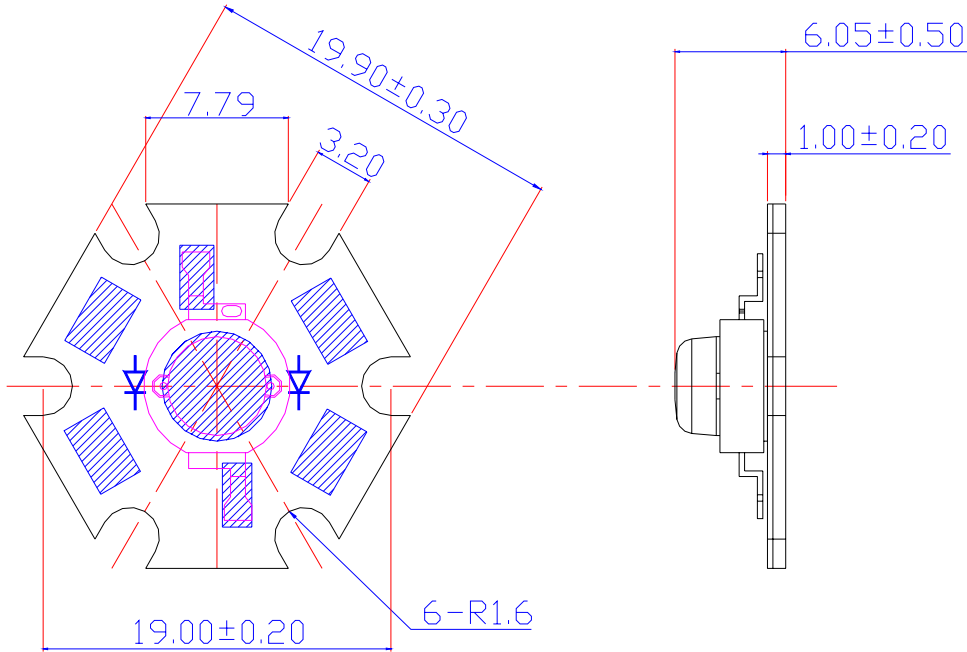

Focusing Star Package Outlines

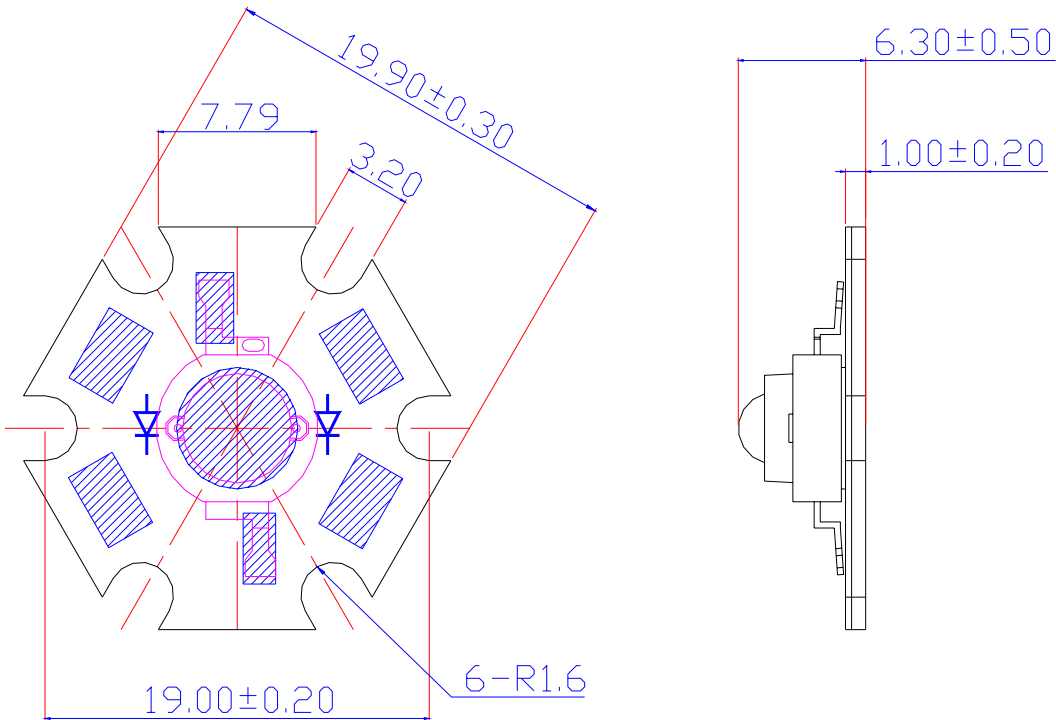

Unit:mm

Absolute Maximum Ratings

Parameter	Symbol	Rating	Units
DC Forward Current	I_F	350	mA
Peak pulse current; ($t_p \leq 100\mu s$, Duty cycle=0.005) ^{*1}	I_{pulse}	1000	mA
Reverse Voltage	V_R	5	V
LED junction Temperature (at 350 mA)	T_j	125	°C
Operating Temperature	T_{opr}	-30 ~ +110	°C
Storage Temperature	T_{stg}	-40 ~ +120	°C
Manual Soldering Time at 260°C (Max.)	T_{sol}	5	seconds

1. Duty cycle:

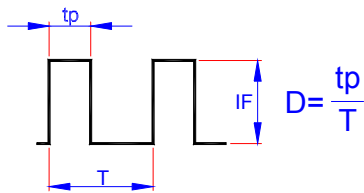

Luminous Flux

Characteristics at $I_F=350mA(T_a=25^\circ C)$:

Lens Item	Part Name	Color	Flux			Units
			Min.	Typ.	Max.	
Lambertian	EDSW-1Lx1	White	23.3	40.0	--	lm
	EDSX-1Lx1	Warm White	17.9	22.0	--	lm
	EDSR-1Lx3	Red	17.9	26.0	--	lm
	EDSO-1Lx3	Red Orange	23.3	35.0	--	lm
	EDSA-1Lx3	Amber	23.3	30.0	--	lm
	EDST-1Lx2	True Green	23.3	35.0	--	lm
	EDSB-1Lx1	Blue	6.3	10.0	--	lm

Lens Item	Part Name	Color	Flux			Units
			Min.	Typ.	Max.	
Batwing Focusing Side Emitting	EDSW-1xx1	White	23.3	36.0	--	lm
	EDSX-1xx1	Warm White	17.9	20.0	--	lm
	EDSR-1xx3	Red	17.9	23.0	--	lm
	EDSO-1xx3	Red Orange	23.3	32.0	--	lm
	EDSA-1xx3	Amber	23.3	27.0	--	lm
	EDST-1xx2	True Green	23.3	32.0	--	lm
	EDSB-1xx1	Blue	6.3	9.0	--	lm

Forward Voltage

Characteristics at $I_F=350mA(T_a=25^\circ C)$:

Lens Item	Part Name	Color	V_F			Units
			Min.	Typ.	Max.	
Lambertian Side Emitting Batwing Focusing	EDSW-1xx1	White	2.8	--	4.0	V
	EDSX-1xx1	Warm White	2.8	--	4.0	V
	EDSR-1xx3	Red	2.0	--	2.75	V
	EDSO-1xx3	Red Orange	2.0	--	2.75	V
	EDSA-1xx3	Amber	2.0	--	2.75	V
	EDST-1xx2	True Green	2.8	--	4.0	V
	EDSB-1xx1	Blue	2.8	--	4.0	V

Wavelength or Color Temperature

Characteristics at $I_F=350mA(T_a=25^\circ C)$:

Lens Item	Part Name	Color	λ_d/CCT			Units
			Min.	Typ.	Max.	
Lambertian Side Emitting Batwing Focusing	EDSW-1xx1	White	5000	--	8000	K
	EDSX-1xx1	Warm White	2800	--	3800	K
	EDSR-1xx3	Red	620	--	630	nm
	EDSO-1xx3	Red Orange	610	--	620	nm
	EDSA-1xx3	Amber	585	--	595	nm
	EDST-1xx2	True Green	515	--	535	nm
	EDSB-1xx1	Blue	460	--	475	nm

Thermal Resistance Junction to Board
Characteristics at $I_F=350mA(T_a=25^\circ C)$:

Lens Item	Part Name	Color	R θ_{J-B}			Units
			Min.	Typ.	Max.	
Lambertian Side Emitting Batwing Focusing	EDSW-1xx1	White	--	15	--	$^\circ C/W$
	EDSX-1xx1	Warm White	--	15	--	$^\circ C/W$
	EDSR-1xx3	Red	--	15	--	$^\circ C/W$
	EDSO-1xx3	Red Orange	--	15	--	$^\circ C/W$
	EDSA-1xx3	Amber	--	15	--	$^\circ C/W$
	EDST-1xx2	True Green	--	15	--	$^\circ C/W$
	EDSB-1xx1	Blue	--	15	--	$^\circ C/W$

Temperature Coefficient Of Forward Voltage
Characteristics at $I_F=350mA(T_a=25^\circ C)$:

Lens Item	Part Name	Color	$\Delta V_F/\Delta T$			Units
			Min.	Typ.	Max.	
Lambertian Side Emitting Batwing Focusing	EDSW-1xx1	White	--	-2	--	mV/ $^\circ C$
	EDSX-1xx1	Warm White	--	-2	--	mV/ $^\circ C$
	EDSR-1xx3	Red	--	-2	--	mV/ $^\circ C$
	EDSO-1xx3	Red Orange	--	-2	--	mV/ $^\circ C$
	EDSA-1xx3	Amber	--	-2	--	mV/ $^\circ C$
	EDST-1xx2	True Green	--	-2	--	mV/ $^\circ C$
	EDSB-1xx1	Blue	--	-2	--	mV/ $^\circ C$

Reverse Current

Characteristics at $V_R=5V(T_a=25^\circ C)$:

Lens Item	Part Name	Color	$I_R(V_R=5V)$			Units
			Min.	Typ.	Max.	
Lambertian Side Emitting Batwing Focusing	EDSW-1xx1	White	--	--	50	μA
	EDSX-1xx1	Warm White	--	--	50	μA
	EDSR-1xx3	Red	--	--	50	μA
	EDSO-1xx3	Red Orange	--	--	50	μA
	EDSA-1xx3	Amber	--	--	50	μA
	EDST-1xx2	True Green	--	--	50	μA
	EDSB-1xx1	Blue	--	--	50	μA

Emission Angle

Characteristics at $I_F=350mA$ ($T_a=25^\circ C$):

Lens Item	Part Name	Color	$2\Theta^{1/2}$			Units
			Min.	Typ.	Max.	
Lambertian	EDSW-1Lx1	White	--	140	--	Degrees
	EDSX-1Lx1	Warm White	--	140	--	Degrees
	EDSR-1Lx3	Red	--	120	--	Degrees
	EDSO-1Lx3	Red Orange	--	120	--	Degrees
	EDSA-1Lx3	Amber	--	120	--	Degrees
	EDST-1Lx2	True Green	--	140	--	Degrees
	EDSB-1Lx1	Blue	--	140	--	Degrees

Lens Item	Part Name	Color	Θ_{PEAK}			Units
			Min.	Typ.	Max.	
Side Emitting	EDSW-1Sx1	White	--	80	--	Degrees
	EDSX-1Sx1	Warm White	--	80	--	Degrees
	EDSR-1Sx3	Red	--	75	--	Degrees
	EDSO-1Sx3	Red Orange	--	75	--	Degrees
	EDSA-1Sx3	Amber	--	75	--	Degrees
	EDST-1Sx2	True Green	--	80	--	Degrees
	EDSB-1Sx1	Blue	--	80	--	Degrees

Emission Angle

Characteristics at $I_F=350mA(T_a=25^\circ C)$:

Lens Item	Part Name	Color	$2\Theta^{1/2}$			Units
			Min.	Typ.	Max.	
Focusing	EDSW-1Fx1	White	--	85	--	Degrees
	EDSX-1Fx1	Warm White	--	85	--	Degrees
	EDSR-1Fx3	Red	--	55	--	Degrees
	EDSO-1Fx3	Red Orange	--	55	--	Degrees
	EDSA-1Fx3	Amber	--	55	--	Degrees
	EDST-1Fx2	True Green	--	60	--	Degrees
	EDSB-1Fx1	Blue	--	60	--	Degrees

Lens Item	Part Name	Color	$2\Theta^{1/2}$	Θ_{PEAK}	Units
			Typ.	Typ.	
Batwing	EDSW-1Bx1	White	110	40	Degrees
	EDSX-1Bx1	Warm White	110	40	Degrees
	EDSR-1Bx3	Red	110	35	Degrees
	EDSO-1Bx3	Red Orange	110	35	Degrees
	EDSA-1Bx3	Amber	110	35	Degrees
	EDST-1Bx2	True Green	110	40	Degrees
	EDSB-1Bx1	Blue	110	40	Degrees

Note

1. Flux is measured with an accuracy of $\pm 15\%$.
2. CCT selection acc. to CCT groups and an accuracy of $\pm 400K$
3. Forward Voltage is measured with an accuracy of $\pm 0.2V$.
4. Wavelength is measured with an accuracy of $\pm 3nm$
5. Angle is measured with an accuracy of ± 15 degree

Electrical & Optical Curves

Wavelength Spectrum

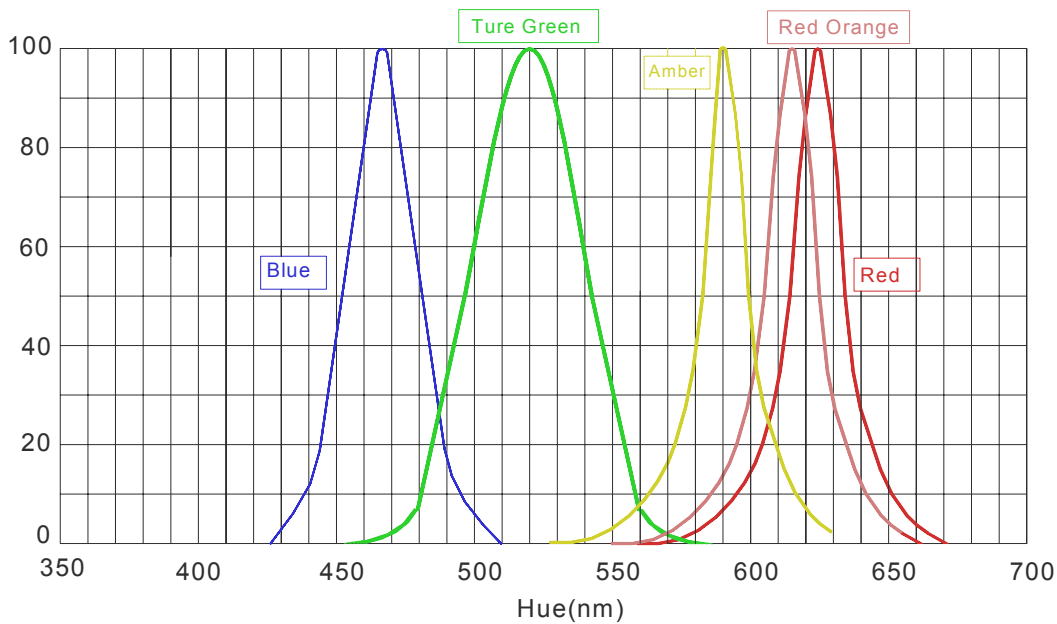
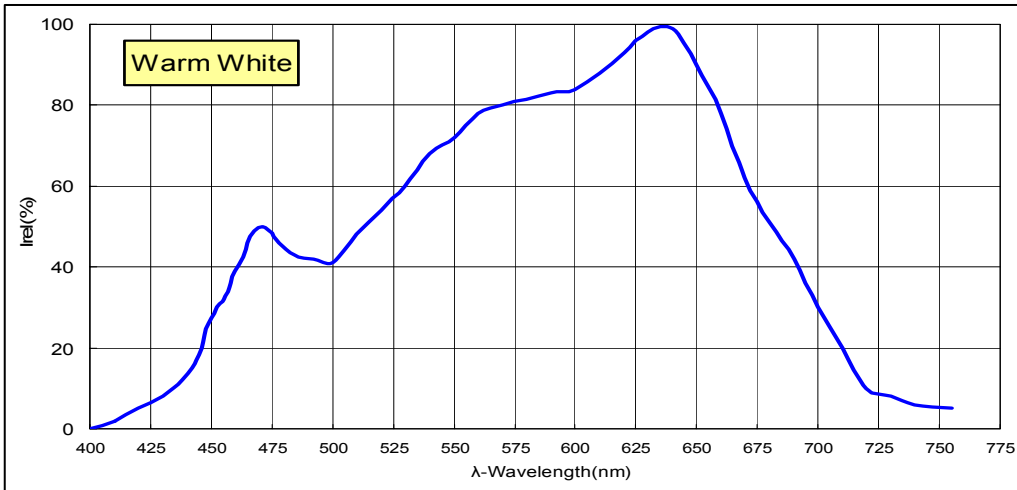
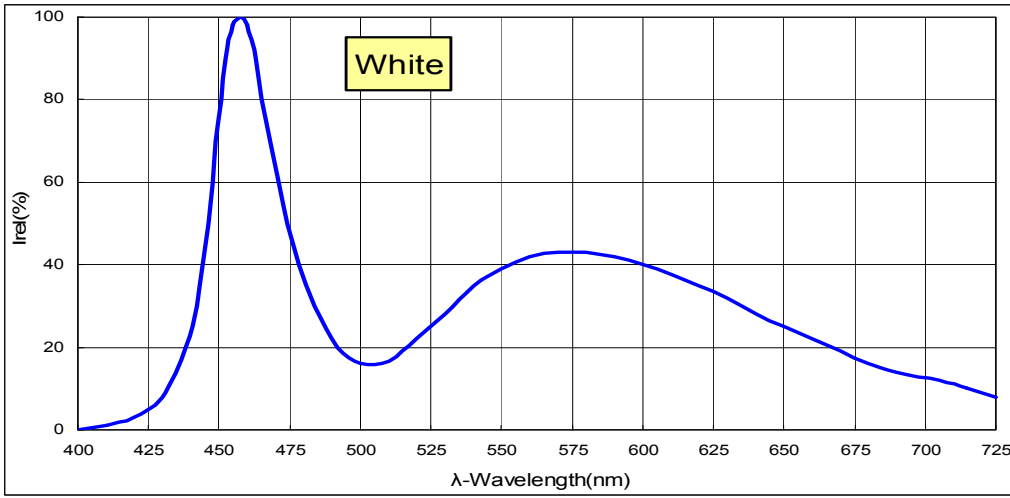

Typical Radiation Pattern for Lambertian

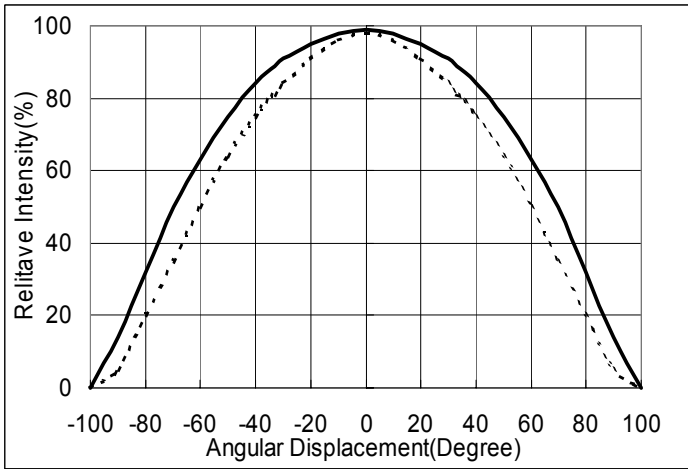

Typical Radiation Pattern for Side Emitting

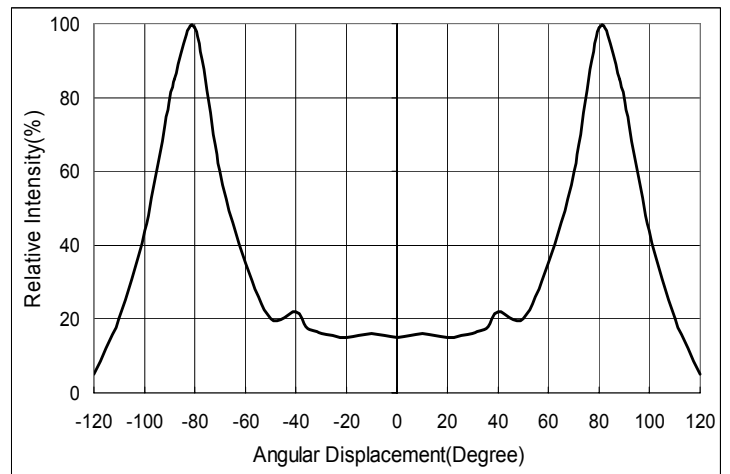

Typical Radiation Pattern for Batwing

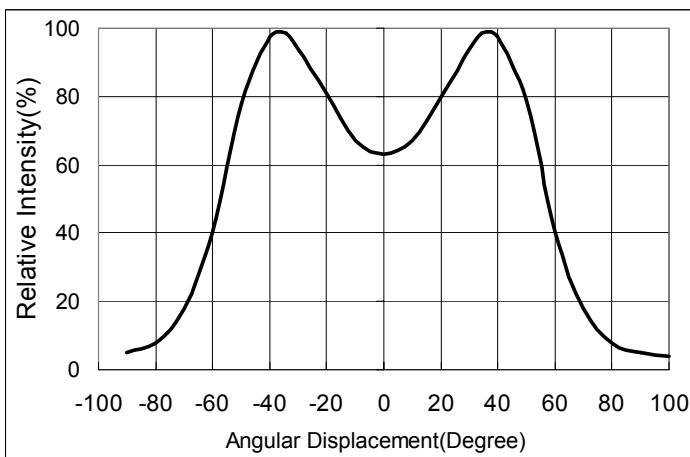

Typical Radiation Pattern for Focusing

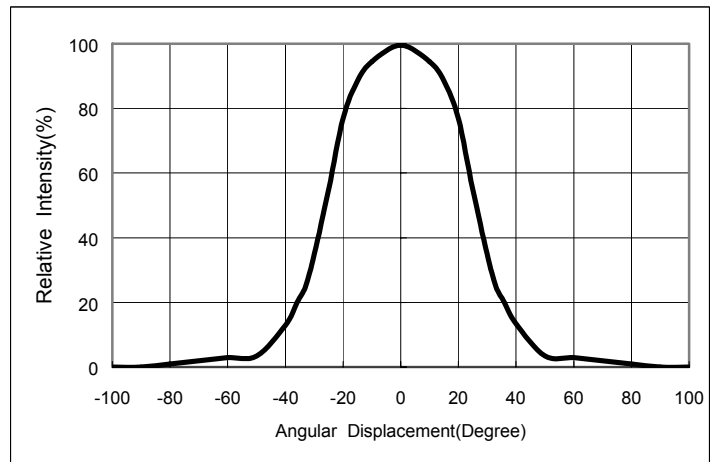

Operating Current & Ambient Temperature

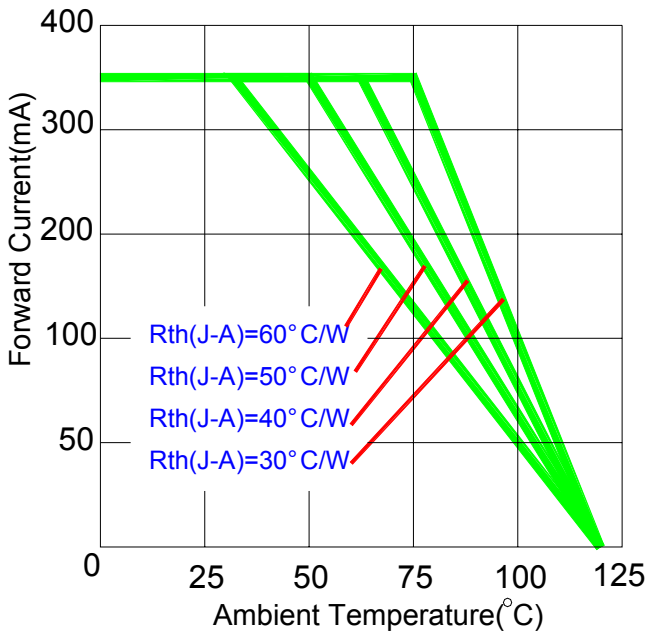

Current & Luminous Flux

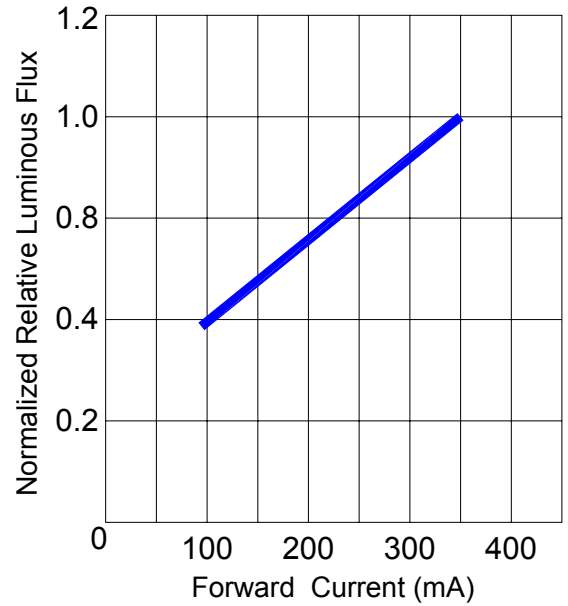

Operating Current & Forward Voltage

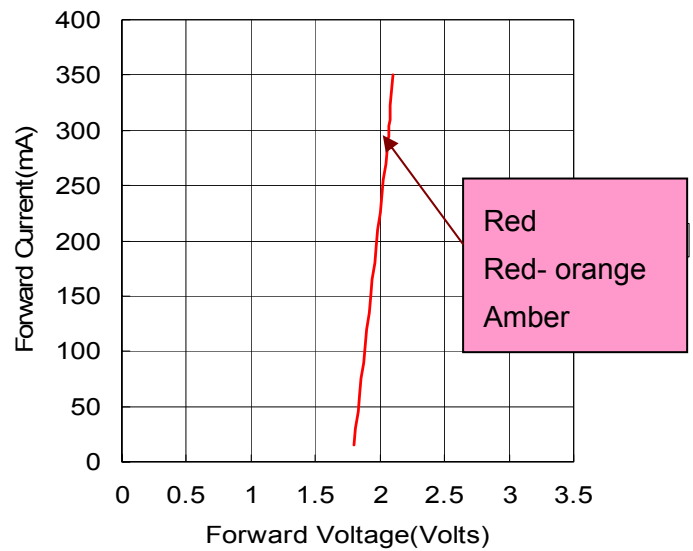
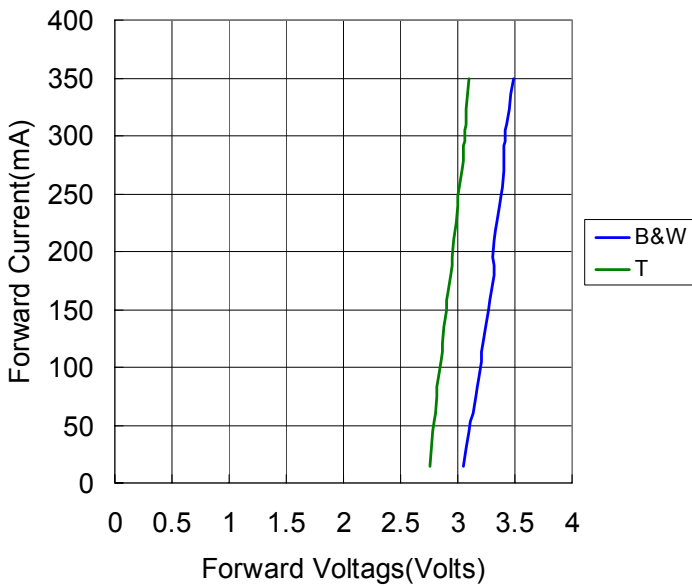

Light Output & Junction Temperature

