

High Power LED

Edixeon™ Emitter

RGB RC Edixeon™

| Approved By Customer | Designer | Checker | Approval |
|----------------------|----------|---------|----------|
| | | | |

Date : 2006/02/07

Version : 1.0

Device No. : 3-RD-01-E0018
EDISON OPTO CORPORATION
4F, No. 800, Chung-Cheng Rd,
Chung-Ho, Taipei 235, Taiwan
Tel: 886-2-8227-6996
Fax: 886-2-8227-6997
<http://www.edison-opto.com.tw>



RGB RC EdixeonTM

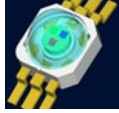

RGB RC Edixeon emitters are one of the highest flux LEDs in the world by Edison Opto. It is designed to satisfy applications of Solid-State lighting. It is designed by three chips to have one package. It has various colors for choice and can be independently controlled. More important, it can be pass reflow process.

Features

- Three chips (color) in one package
- Various colors for choice
- Independent control of each color
- More energy efficient than incandescent and most halogen lamps
- Low voltage operated
- Instant light
- Long operating life
- IR reflow process compatible

Typical Applications

- Up-lighters and Down-lighters
- Contour lights
- Ceiling lights
- Garden lighting
- Architectural lighting
- Beacon lights



Package Outlines

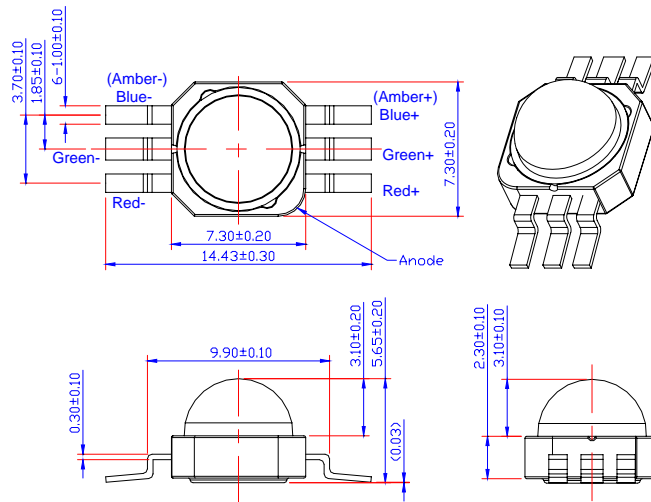

Notes:

1. All dimensions are in mm.
2. Drawings are not to scale.
3. It is strongly recommended that the temperature of lead be not higher than 55°C.
4. It is important that the slug can't be contact aluminum surface, It is strongly recommended that there should coat a uniform electrically isolated heat dissipation film on the aluminum surface.

Absolute Maximum Ratings

| Parameter | Symbol | Rating | Units |
|--|-------------|------------|---------|
| DC Forward Current | I_F | 350 | mA |
| Peak pulse current;(tp ≤ 100μs, Duty cycle=0.25) | I_{pulse} | 500 | mA |
| Reverse Voltage | V_R | 5 | V |
| Reverse Current($V_R=5V$) | I_R | 50 | μA |
| LED junction Temperature (at 350 mA) | T_j | 125 | °C |
| Operating Temperature | T_{opr} | -30 ~ +130 | °C |
| Storage Temperature | T_{stg} | -40 ~ +150 | °C |
| Manual Soldering Time at 260°C (Max.) | T_{sol} | 5 | seconds |

Luminous Flux Characteristics at $I_F=350mA(T_a=25°C, T_{opr}=100ms)$:

| Part Name | Color | Flux | | | Units |
|-------------|------------|------|------|------|-------|
| | | Min. | Typ. | Max. | |
| EDERTB-1LC6 | Red | 13.8 | 26 | -- | lm |
| | True Green | 17.9 | 32 | -- | lm |
| | Blue | 4.8 | 10 | -- | lm |
| EDERTA-1LC6 | Red | 13.8 | 26 | -- | lm |
| | True Green | 17.9 | 32 | -- | lm |
| | Amber | 13.8 | 26 | -- | lm |

Forward Voltage Characteristics at $I_F=350mA(T_a=25°C, T_{opr}=100ms)$:

| Part Name | Color | V_F | | | Units |
|-------------|------------|-------|------|------|-------|
| | | Min. | Typ. | Max. | |
| EDERTB-1LC6 | Red | -- | 2.5 | -- | V |
| | True Green | -- | 3.6 | -- | V |
| | Blue | -- | 4.0 | -- | V |
| EDERTA-1LC6 | Red | -- | 2.5 | -- | V |
| | True Green | -- | 3.6 | -- | V |
| | Amber | -- | 2.5 | -- | V |

Dominant Wavelength Characteristics at $I_F=350\text{mA}$ ($T_a=25^\circ\text{C}$, $T_{opr}=100\text{ms}$):

| Part Name | Color | λ_d | | | Units |
|-------------|------------|-------------|------|------|-------|
| | | Min. | Typ. | Max. | |
| EDERTB-1LC6 | Red | 620 | -- | 630 | nm |
| | True Green | 505 | -- | 525 | nm |
| | Blue | 460 | -- | 475 | nm |
| EDERTA-1LC6 | Red | 620 | -- | 630 | nm |
| | True Green | 505 | -- | 525 | nm |
| | Amber | 585 | -- | 595 | nm |

Thermal Resistance Junction to Board at $I_F=350\text{mA}$ ($T_a=25^\circ\text{C}$, $T_{opr}=100\text{ms}$):

| Part Name | Color | R_{th} | | | Units |
|-------------|------------|----------|------|------|---------------------------|
| | | Min. | Typ. | Max. | |
| EDERTB-1LC6 | Red | -- | 15 | -- | $^\circ\text{C}/\text{W}$ |
| | True Green | -- | 15 | -- | $^\circ\text{C}/\text{W}$ |
| | Blue | -- | 15 | -- | $^\circ\text{C}/\text{W}$ |
| EDERTA-1LC6 | Red | -- | 15 | -- | $^\circ\text{C}/\text{W}$ |
| | True Green | -- | 15 | -- | $^\circ\text{C}/\text{W}$ |
| | Amber | -- | 15 | -- | $^\circ\text{C}/\text{W}$ |

Temperature coefficient of forward voltage Thermal Resistance Junction to Board at $I_F=350\text{mA}$ ($T_a=25^\circ\text{C}$, $T_{opr}=100\text{ms}$):

| Lens Item | Color | $\Delta V_f/\Delta T$ | | $R\theta_{J-B}$ | |
|-------------|------------|-----------------------|----------------------------|-----------------|---------------------------|
| | | Typ. | Units | Typ. | Units |
| EDERTB-1LC6 | Red | -2 | $\text{mV}/^\circ\text{C}$ | 20 | $^\circ\text{C}/\text{W}$ |
| | True Green | -2 | $\text{mV}/^\circ\text{C}$ | 20 | $^\circ\text{C}/\text{W}$ |
| | Blue | -2 | $\text{mV}/^\circ\text{C}$ | 20 | $^\circ\text{C}/\text{W}$ |
| EDERTA-1LC6 | Red | -2 | $\text{mV}/^\circ\text{C}$ | 20 | $^\circ\text{C}/\text{W}$ |
| | True Green | -2 | $\text{mV}/^\circ\text{C}$ | 20 | $^\circ\text{C}/\text{W}$ |
| | Amber | -2 | $\text{mV}/^\circ\text{C}$ | 20 | $^\circ\text{C}/\text{W}$ |

Note

1. Flux is measured with an accuracy of $\pm 10\%$.
2. Forward Voltage is measured with an accuracy of $\pm 0.1\text{V}$
3. Wavelength is measured with an accuracy of $\pm 0.5\text{nm}$
5. All True green and blue emitters are built with InGaN
6. All red, red-orange and amber emitters are built with AlGaInP

Spectrum

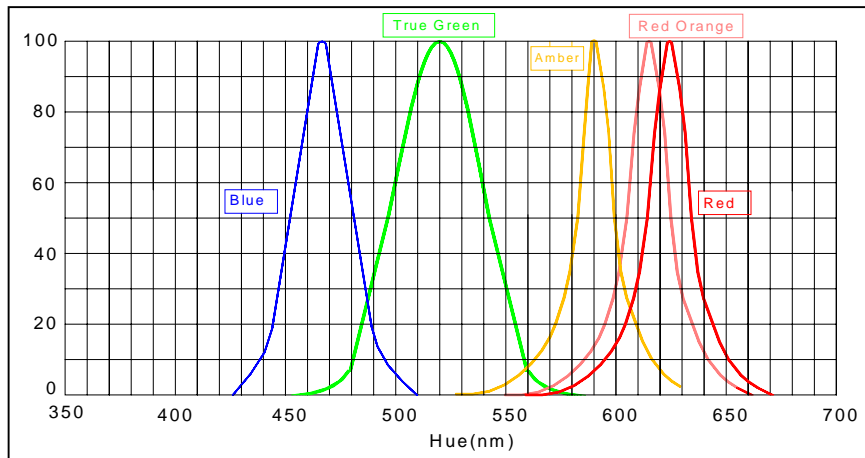

Junction temperature & Relative Flux

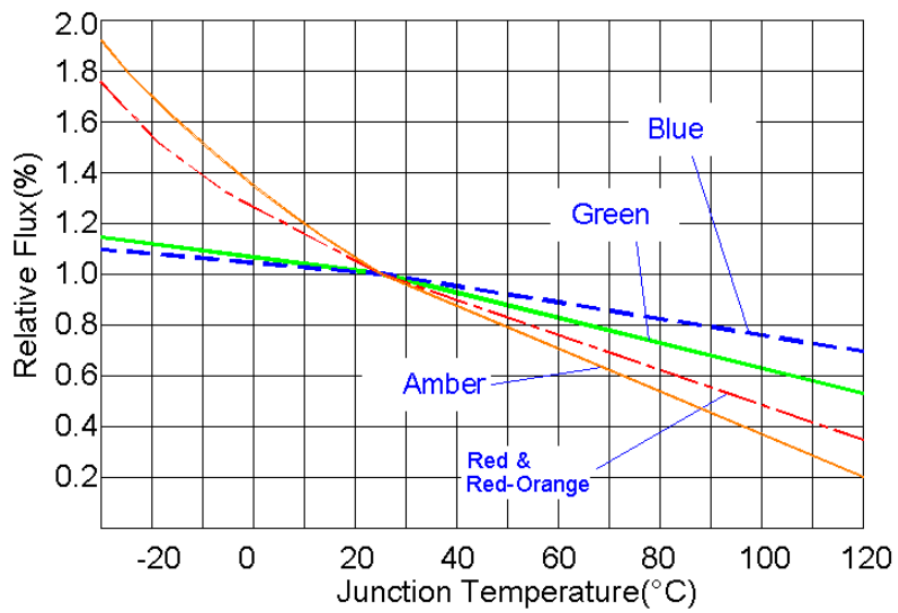

Typical Radiation Pattern for Lambertian

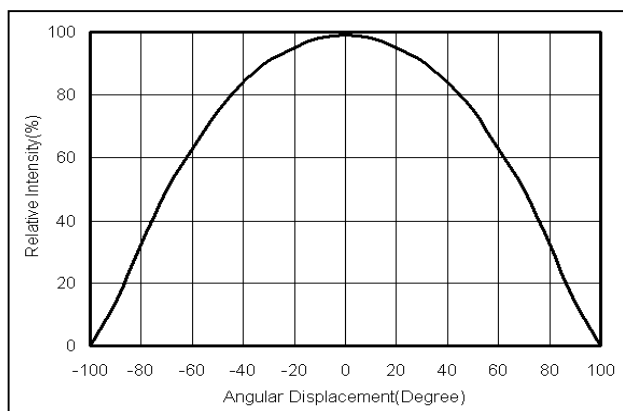

Typical Optical and Electrical Curves

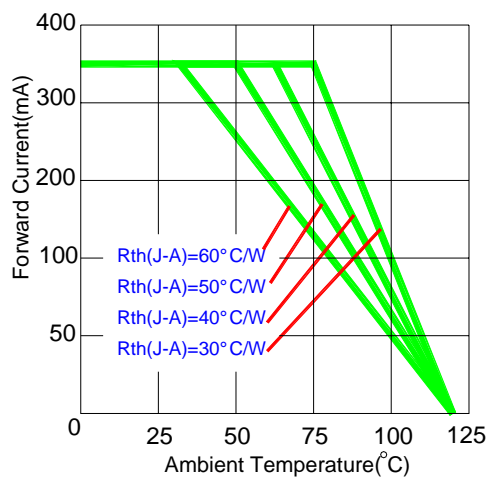

Operating Current & Ambient Temperature

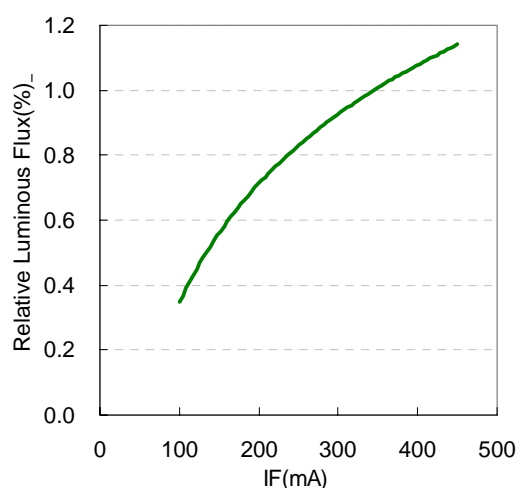

Forward Current & Luminous Flux

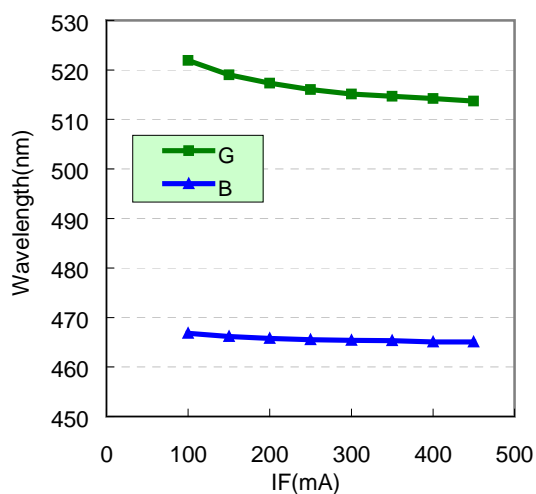

Forward Current & Wavelength

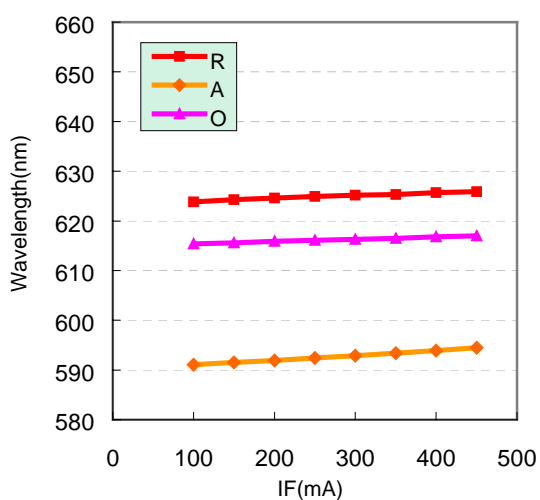

Recommend Solder Pad Design

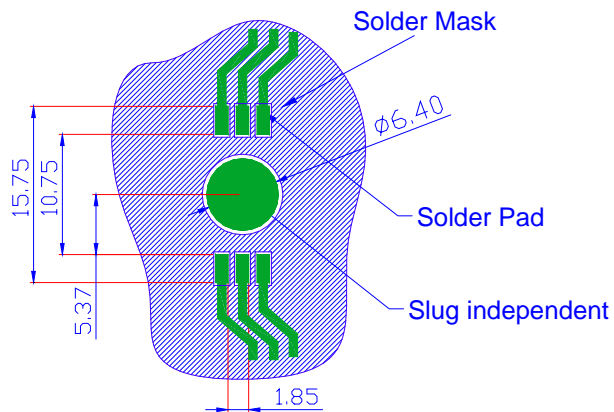

Note:

1. All dimensions are in mm.
2. The drawings are not to scale.
3. Solder pad can't be connected to slug.

Recommend Solder Steps

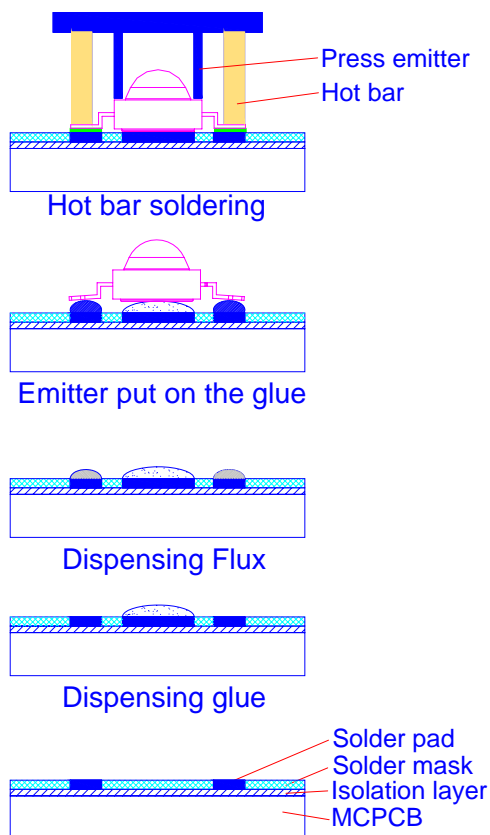

Notes:

1. MCPCB material with a thermal conductivity greater than 2.0 W/mK.
2. Solder pad can't be connected to slug.
3. The Thermal glue should be as thin as possible for better heat conductivity.
4. During any assembly process touching lens is avoided. This will cause pollution or scratch on the surface of lens.

IR reflow Soldering Profile. (acc. to IPC 9501)

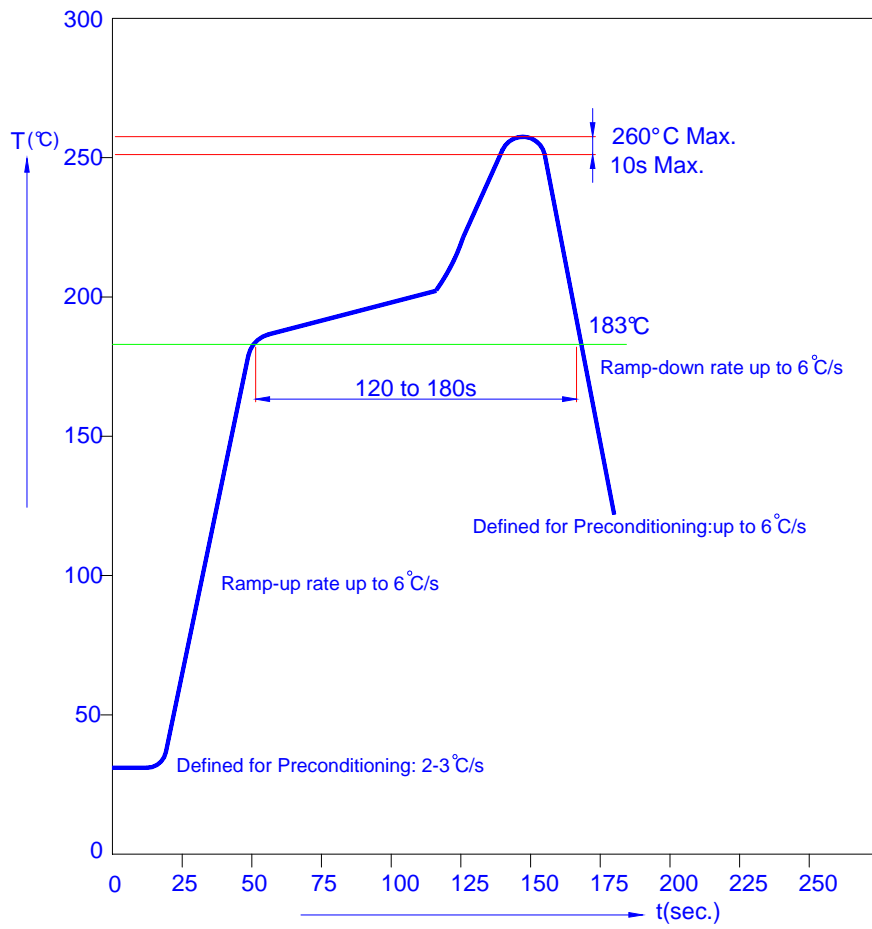

Package Specifications

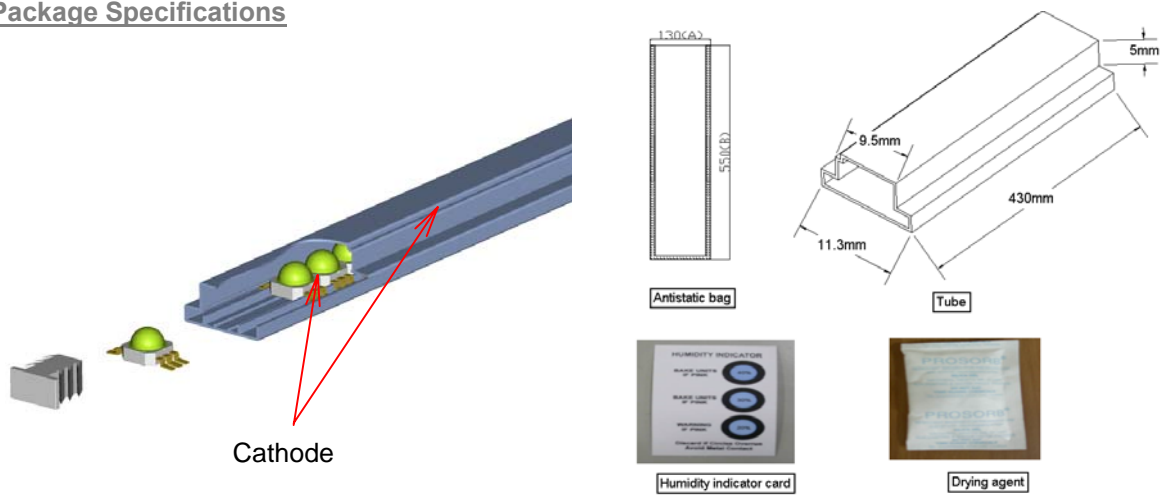

Note

1. All dimensions are in mm.
2. There are 50pcs emitters in a tube.
3. There are 20 tubes in a bag.
4. There are 2 bags in a inner box.
5. A bag contains one humidity indicator card and drying agent.