



High Power LED

Ultraviolet EdixeonTM

Approved By Customer	Designer	Checker	Approval

Date : 2006/05/12

Version : 1.0

Device No. : 3-RD-01-E0034
EDISON OPTO CORPORATION
4F, No. 800, Chung-Cheng Rd,
Chung-Ho, Taipei 235, Taiwan
Tel: 886-2-8227-6996
Fax: 886-2-8227-6997
<http://www.edison-opto.com.tw>



Ultraviolet EdixeonTM



Ultraviolet Edixeon emitters are one of the highest power LEDs in the world by Edison Opto. Ultraviolet Edixeon are designed for ultraviolet curing.

Features

- Low voltage operated
- Long operating life

Typical Applications

- Ultraviolet curing



Absolute Maximum Ratings

Parameter	Symbol	Rating	Units
DC Forward Current for 1W	I_F	350	mA
DC Forward Current for 3W	I_F	700	mA
1W emitter Peak pulse current;(tp≤100μs, Duty cycle=0.25)	I_{pulse}	1000	mA
3W emitter Peak pulse current;(tp≤100μs, Duty cycle=0.25)	I_{pulse}	1400	mA
Reverse Voltage	V_R	5	V
LED junction Temperature (1W at 350 mA ,3W at 700mA)	T_j	125	°C
Operating Temperature	T_{opr}	-30 ~ +110	°C
Storage Temperature	T_{stg}	-40 ~ +120	°C
Manual Soldering Time at 260°C (Max.)	T_{sol}	5	seconds

Electric and Optical Characteristics 1W at $I_F=350mA$ & 3W at $I_F=700mA$

($T_a=25^{\circ}C, T_{opr}=100ms$):

Part No.	Item	Symbol	Value			Units
			Min.	Typ.	Max.	
EDEV-1LA1	Radiometric Power	Φ_V	113.9	180	--	mW
EDEV-3LA1			256.3	350	--	mW
EDEV-1LA1	Peak Wavelength	λ_P	395	--	410	nm
EDEV-3LA1			395	--	410	nm
EDEV-1LA1	Forward Voltage	V_F	2.8	3.5	4.0	V
EDEV-3LA1			2.8	3.5	4.0	V
EDEV-1LA1	Emission Angle	$2\theta_{1/2}$	--	140	--	Degree
EDEV-3LA1			--	140	--	Degree
EDEV-1LA1	Thermal Resistance	$R_{\theta_{J-B}}$	--	20	--	°C/W
EDEV-3LA1			--	10	--	°C/W

Note

1. Radiometric power is measured with an accuracy of $\pm 10\%$.
2. Forward Voltage is measured with an accuracy of $\pm 0.1V$
3. Wavelength is measured with an accuracy of $\pm 0.5nm$
4. All emitters are built with InGaN

Typical Radiation Pattern

Lambertian

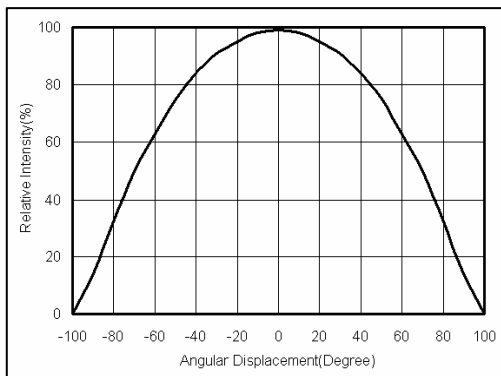

Typical Optical and Electrical Curves

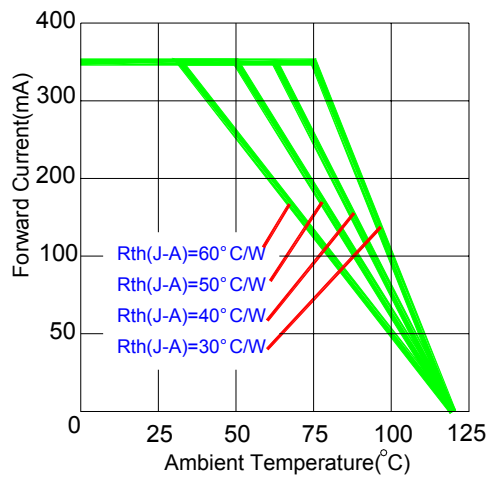

Operating Current & Ambient Temperature
For 1W emitter

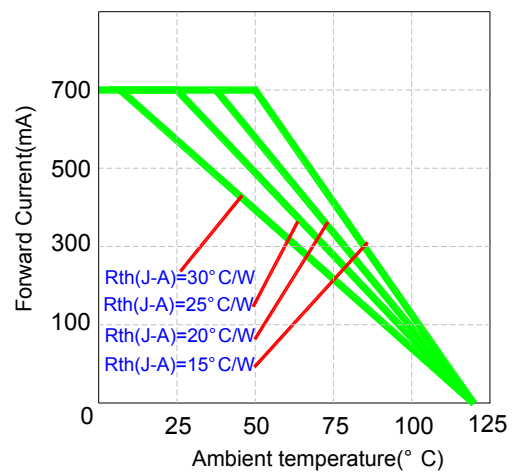

Forward Current & Luminous Flux
For 3W emitter

Recommend Solder Pad Design

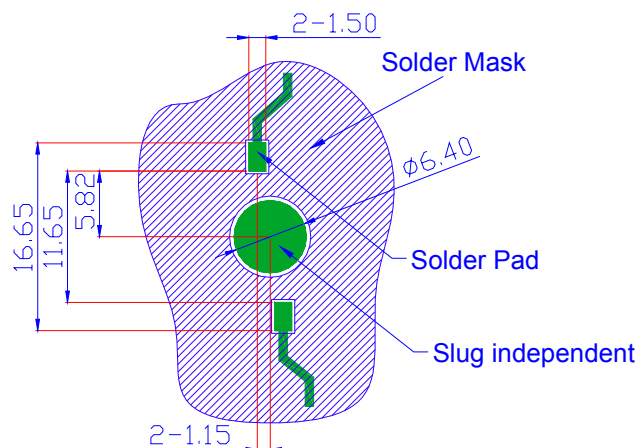

Note:

1. All dimensions are in mm.
2. The drawings are not to scale
3. Solder pad can't be connected to slug.

Recommend Solder Steps

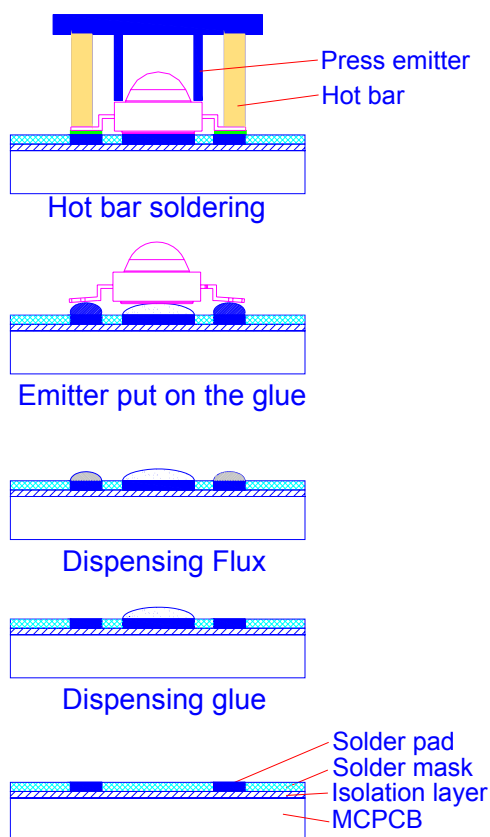

Notes:

1. MCPCB material with a thermal conductivity greater than 2.0 W/mK.
2. Solder pad can't be connected to slug.
3. The Thermal glue should be as thin as possible for better heat conductivity.
4. During any assembly process touching lens is avoided. This will cause pollution or scratch on the surface of lens.

Package Specifications

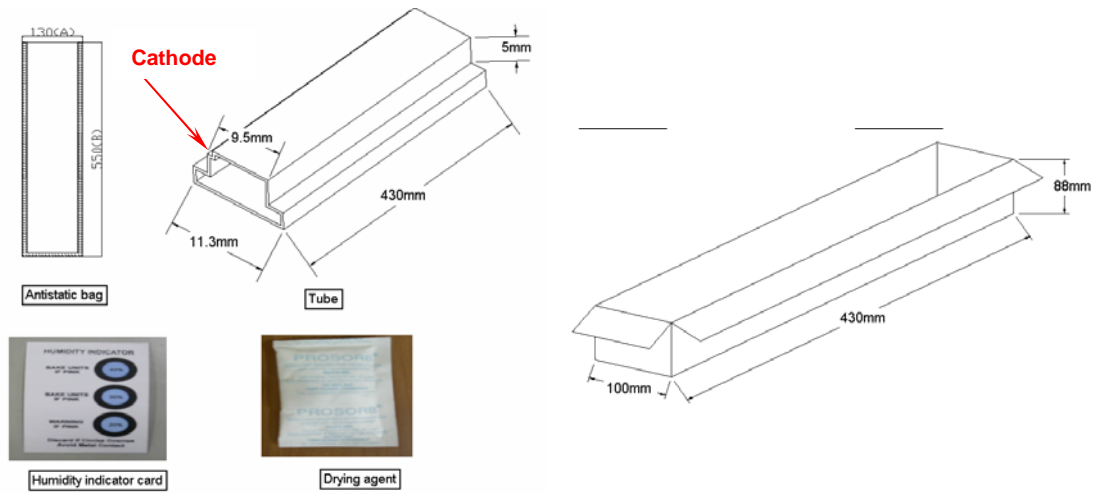

Note

1. All dimensions are in mm.
2. There are 50pcs emitters in a tube
3. There are 20 tubes in a bag
4. There are 2 bags in a inner box
5. A bag contains one humidity indicator card and drying agent